



P513-173

# B252PD



B-Series Double Cylinder Locks

Installation instructions

## Parts Included

- (2) Keys
- (1) Inside cylinder
- (1) Outside cylinder
- (2) 7/16" (11 mm) rings & hardened steel inserts
- (2) 1/8" (3 mm) ring and hardened steel insert
- (2) Driver bar sets
- (1) Latch
- (2) Mounting screws, cylinders
- (1) Inside cylinder faceplate
- (1) Strike
- (1) Strike dust box
- (1) Strike reinforcer
- (2) 3" (76 mm) mounting screws, reinforcer
- (4) Mounting screws, latch and strike

Depending on size ordered, included rings and inserts may vary.

## NOTE:

**Hollow metal doors must be properly reinforced for latch support. If door reinforcement is not furnished, contact door manufacturer, or use Schlage reinforcer #37-001 (specify door thickness)**

## 1 Select rings and driver bars.

Use chart to choose rings and driver bars for door thickness.

Door Thickness	Use	5 Pin Cylinder	6 Pin Cylinder
1 3/8" (35 mm)	Rings	B and A	B and (2) A
	Bars	1	3
1 3/4" (44 mm)	Rings	B	B and A
	Bars	2	4

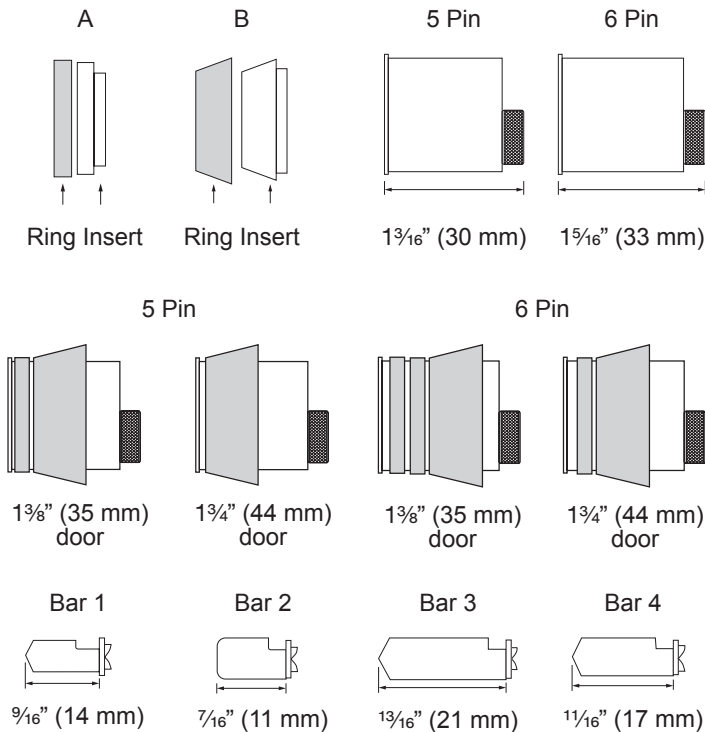

## 2 Prepare the door.

2a Mark centerline on door face and edge.

2b Place template on door and drill a 1 1/2" (38 mm) hole through the door face (from both sides to avoid damaging wood).

Drill a 1" (25 mm) hole in door edge. Drill 3/8" (10 mm) deeper as illustrated.

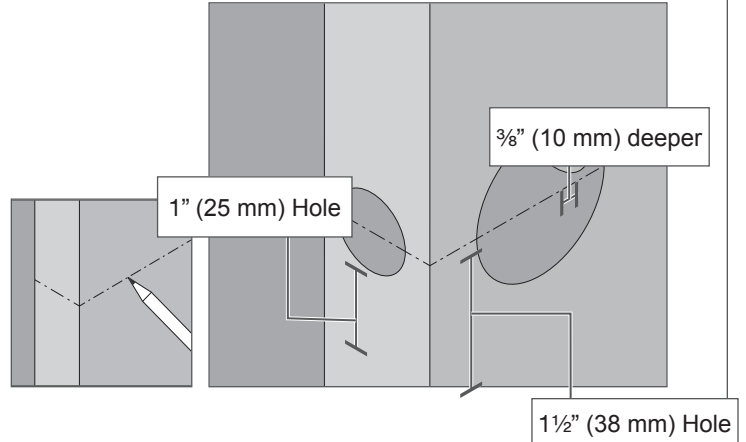

## 3 Install latch.

3a Rotate to adjust latch so that bolt faces door jamb.

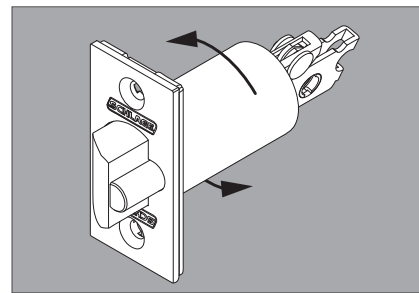

3b Insert latch into hole. Line up and trace around faceplate.

Use chisel to remove wood until the faceplate fits flush when latch is fully inserted.

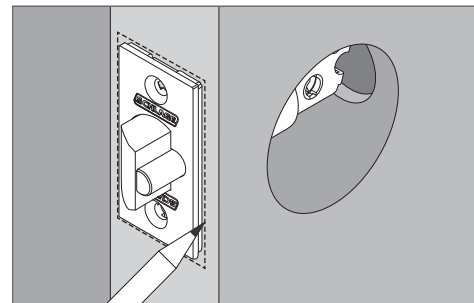

3c Install latch with provided screws.

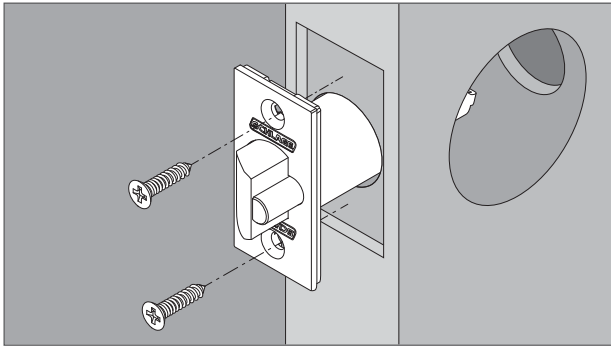

4 Prepare door jamb.

4a Locate exact centerline of latch and mark centerline on door jamb.

Mark drill points  $\frac{1}{4}$ " (6 mm) above and below horizontal centerline. Drill two (2) overlapping  $\frac{7}{8}$ " (22 mm) holes,  $1\frac{1}{16}$ " (17 mm) deep.

Clean out holes for strike box. Use strike as pattern for cutout. Use chisel to remove wood  $\frac{1}{4}$ " (6 mm) deep.

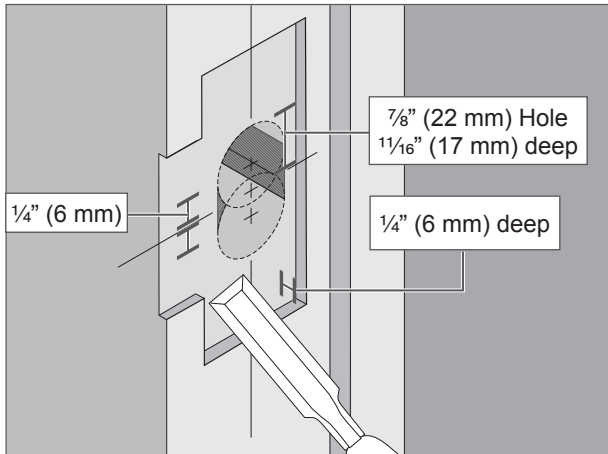

4b Mark and drill  $\frac{3}{16}$ " (4 mm) pilot holes for 3" wood screws.

Install reinforcer, dust box, and strike with provided screws.

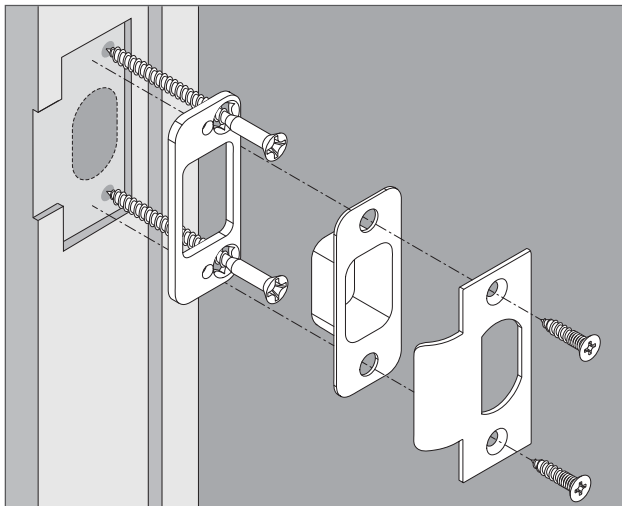

5 Install cylinders.

5a Insert driver bars into cylinders.

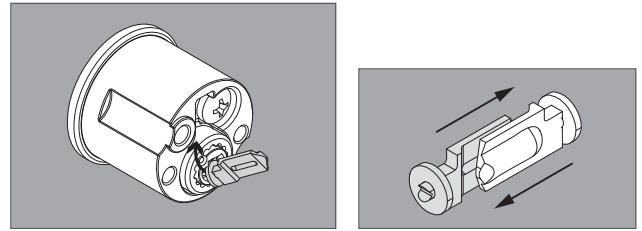

5b With key removed, insert cylinders into rings (see step 1) and guide driver bars into slot in latch.

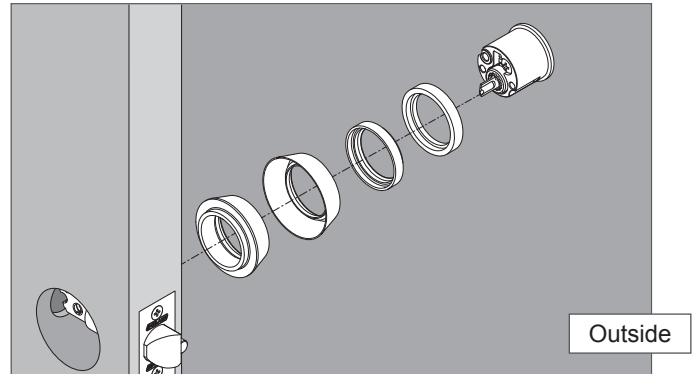

Install faceplate on inside cylinder.

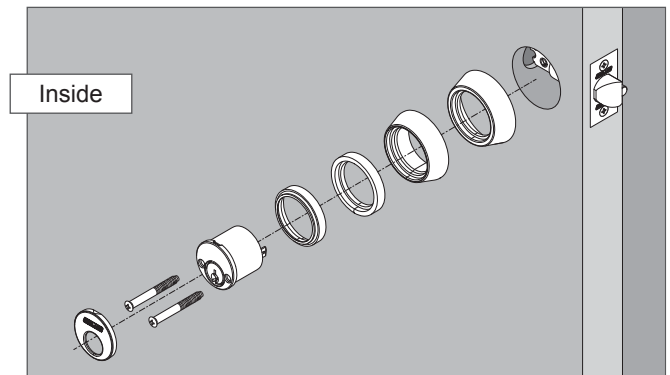

Customer Service

1-877-671-7011

[www.allegion.com/us](http://www.allegion.com/us)

